

Barceló Atom España S.A.
 Avda. Centro Excursionista Eldense, Nave 18
 Apdo: 271. Elda (Alicante)
 Tel.: 965 386 244 Fax: 965 399 236
 info@barceloatom.com

www.barceloatom.com
 C/Londres, 5-11, Interior Nave nº4, -
 Polig.Ind. Cova Solera- 08191 Rubí (Barcelona)
 Tel.: 936 979 793 Fax: 936 972 014
 infoarna@barceloatom.com

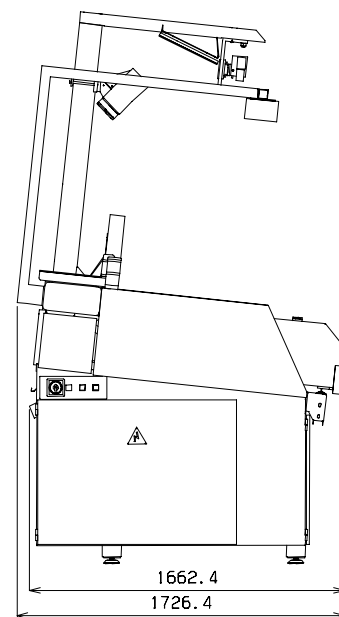
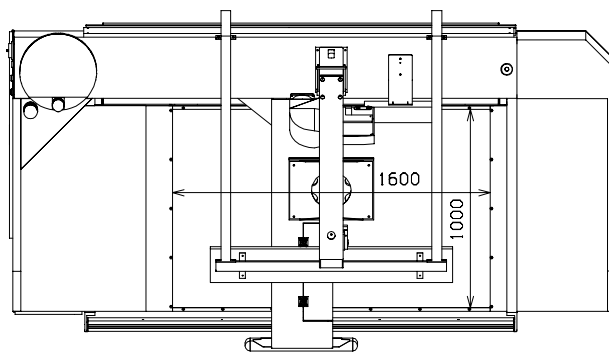
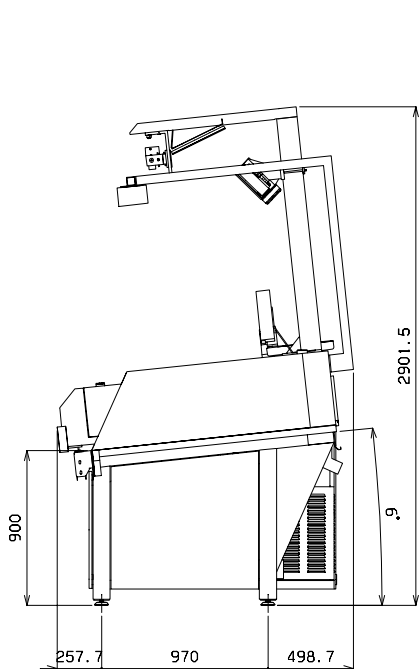
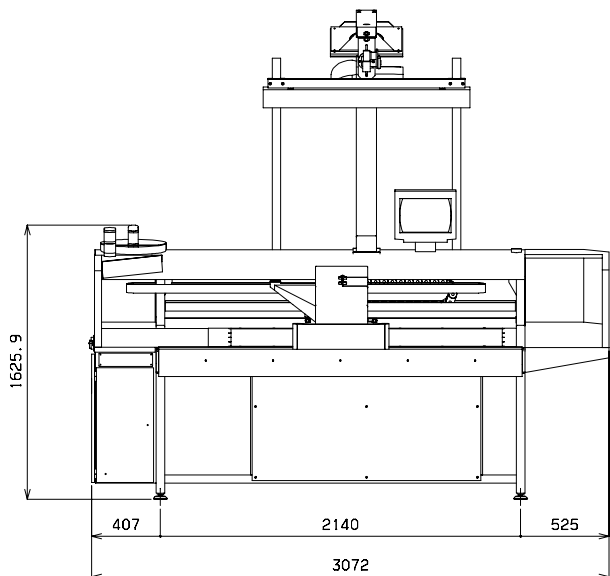

MODEL	Projector number	Camera number	Working areas	Pump numbers	Optional feeder
1610UP (PNEU)	1	1	1	1	Simple roll holder
1610UCP (PNEU)	1	1	1	1	Simple roll holder

Useful working area	1600 x 1000 mm
Max cutting speed	50 m/min
Acceleration	1 g
Head tool number	5
Perforating frequency	220 min
Number of suction sectors	24

Vacuum pump absorption range	3 – 15,2 kW
Vacuum pressure adjustable up to	- 200 mbar
Pneumatic circuit	7 bar – 100 l/min
Pneumatic circuit (PNEU)	9 bar – 400 l/min
Weight	1250 Kg (UP)
Weight	1300 Kg (UCP)
Absorption for power circuit	18,8 kW